

Elevated, chuted ice storage bin and cart systems use gravity to load ice into cart. Exceptional labor-savings, sanitation and safety for foodservice operations using cube ice. Storage capacities from 2110 lbs (957kg) to 4640 lbs (2105kg).



Model DEV2250-72 with SmartCART 75\*

**Easy, safe to use!**

**No motors or augers**

**A better way to remove and transport ice!**



*Ice flows smoothly through chute into Totes when chute door is opened*

### Labor-saving ice removal

- Ice flows smoothly through chute into Totes™ when chute door is opened
- Eliminates need to shovel or scoop ice from bin
- Reduces ice removal time by up to 75%

### Faster, safer ice transport

- Slim, 21.5" (547mm) wide cart safely moves 75 lbs (34kg) of ice through narrow aisles (other cart sizes available)
- Oversized back wheels allow easy rolling over safety mats and uneven floors

### Safe, sanitary, easy ice distribution

- Rugged poly Totes limit lifted weight to 25 lbs (11kg) for safer ice delivery
- Rectangular design facilitates pouring into beverage dispensers, wait stations and ice wells
- Dedicated-use Totes deliver more sanitary ice
- Hinged lid protects ice during transport

### Convenient, safer SMARTGATE® access

- First ice in is first ice out
- Provides positive control of ice flow into access door area
- SMARTGATE slots allow safer breaking of ice bridges through gate, reducing spillage
- Locks open in 3 positions
- Returns easily to full down position even when bin is full

### Durable polyethylene lift doors with PowerHinge™

- Doors stay safely open – no door catches
- No sharp corners to injure workers
- Molded-in gasket never needs replacing
- Easy one-hand open and close

### Highest quality construction

- Non-corroding poly liners eliminate pitting, corrosion, staining
- Stainless steel exterior including back and bottom
- Stainless steel base

### Optional Accessories (refer to form# 3435)

- Additional cart and Totes
- Drain pan (required for some Vogt icemakers; consult factory)
- Center bin partition

\*Other configurations available - consult factory

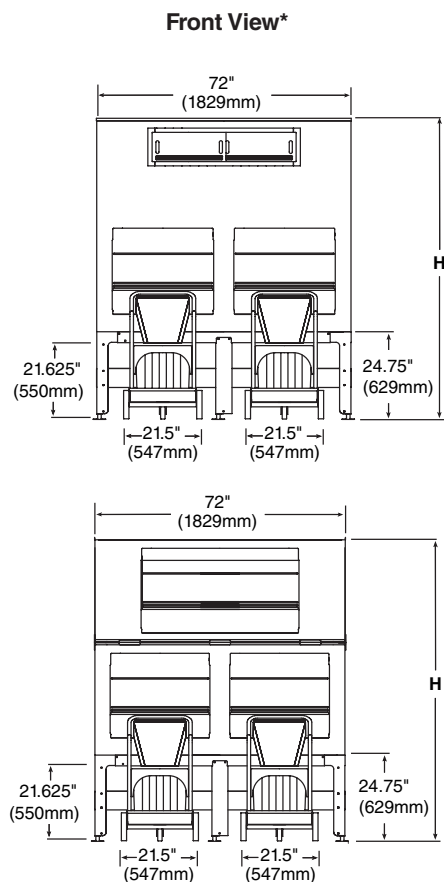

**Models DEV2100, 2250, 2650**

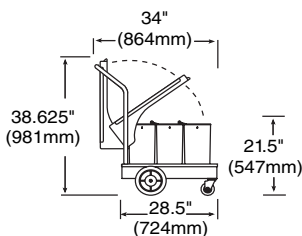

**Models DEV3200, 3900, 4600**

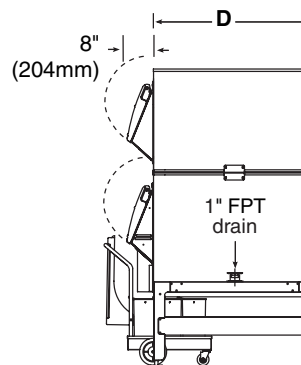
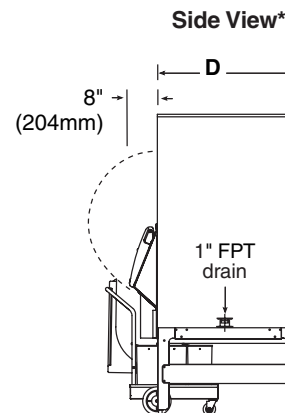
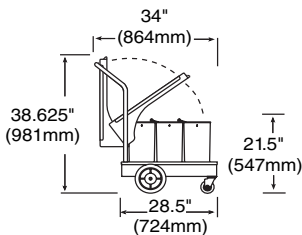

\* Shown with SmartCART 75

**General Notes**

Follett recommends installation of a floor drain with grate with all ice storage bins. Consider cart positioning when locating the drain. Clearance required to pull cart from below bin — minimum 26" (661mm), optimal 40" (1016mm).

Model Number	with SC75 Cart	with SC125 Cart	with Cambro Cart	Cubic Volume cu ft (m)	Max. Bin Capacity lb (kg) <sup>1</sup>	Width in (mm)	Depth in (mm) <sup>2,3,4</sup>	Height in (mm) <sup>5</sup>	Req'd Door Access in (mm) <sup>6</sup>	Approx. Ship Weight lb (kg) <sup>7</sup>
DEV2100SG-72	-75	-125	-ICS125L	59.4 (1.68)	2110 ( 957)	72 (1829)	40 (1016)	75.5 (1918)	41 (1024)	1003 (453)
DEV2250SG-72	-75	-125	-ICS125L	71.5 (2.02)	2250 (1021)	72 (1829)	48 (1220)	69.5 (1766)	46 (1169)	863 (344)
DEV2650SG-72	-75	-125	-ICS125L	84.0 (2.38)	2650 (1202)	72 (1829)	40 (1016)	85.5 (2172)	41 (1024)	996 (452)
DEV3200SG-72	-75	-125	-ICS125L	102.7 (2.90)	3240 (1470)	72 (1829)	48 (1220)	88.5 (2248)	35 ( 889)	1144 (519)
DEV3900SG-72	-75	-125	-ICS125L	125.1 (3.54)	3940 (1787)	72 (1829)	48 (1220)	100.5 (2566)	44 (1118)	1239 (562)
DEV4600SG-72	-75	-125	-ICS125L	147.4 (4.17)	4640 (2105)	72 (1829)	48 (1220)	112.0 (2845)	47 (1194)	1276 (579)

**Notes:**

- 1 Computed on cubic volume of bin. Does not reflect cart capacity or voids that can occur due to pyramiding.
- 2 Add 2" (51mm) to depth and 10 lbs (4.5kg) to shipping weight when drain pan accessory used.
- 3 Add 8" (204mm) to depth (D) for lower door assembly (easily removed for installation access).
- 4 Required clearance for installation access through doors (may require removal of door assembly).
- 5 Special top required for icemakers weighing more than 1000 lbs (454kg). Add 2.125" (54mm) to height. Contact factory.

SMARTGATE is a registered trademark of Follett Corporation, registered in the US. Follett reserves the right to change specifications at any time without obligation. Certifications may vary depending on country of origin.